

Spring Plungers • long version
EH 22070.



Product Description

To be used for ejecting, as a detent, for applying pressure or as a shock element.

Material

Pin

- Steel, case-hardened, black
- Stainless Steel 1.4305, nitrided

Body

- Free cutting steel, blackened
- Stainless steel 1.4305
- Heat-treated steel, tempered, blackened

Spring

- Stainless steel

Assembly

Spring plungers can be mounted and removed by means of the slot or internal hexagon. Please use a special assembly tool for mounting with a slot (pin side).

Characteristic

Standard spring load: no marking
Heavy spring load: marked with two lines

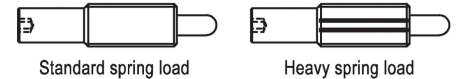

More information

Notes

Special types on request.
Spring plungers are specially tested for spring range and forces.

References

Thread lock: polyamide all-around coating (for details please refer to the technical appendix).

Drawing

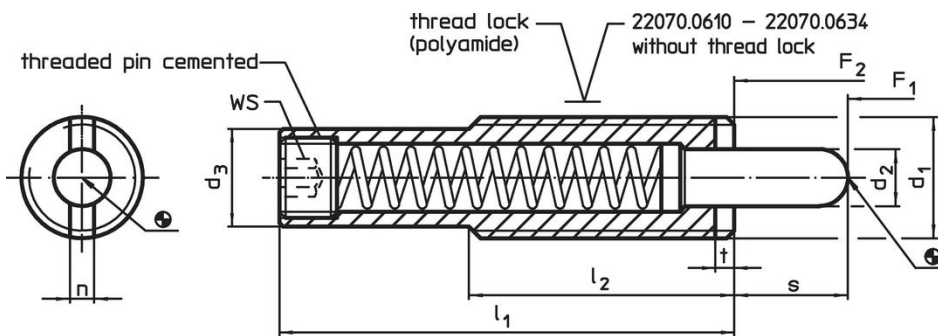

Order information

Dimensions							Stroke s	WS	Spring load ¹⁾		min. max.		[g]	Art. No.
d ₁	d ₂	d ₃	l ₁	l ₂	n	t			F ₁	F ₂	[°C]			
[mm]							[mm]	[mm]	[N]	[N]				
body from free cutting steel, standard spring load, with thread lock														
M10	4.0	7.8	35	25	1.5	1.4	8	3	6	16	-30	90	13	22070.0408
M12	5.5	9.5	43	35	2.7	2.0	10	4	4	18	-30	90	22	22070.0412
M16	8.0	13.4	48	35	3.2	3.0	10	6	7	24	-30	90	47	22070.0430
M16	8.0	13.4	58	35	3.2	3.0	10	6	15	42	-30	90	53	22070.0432
M16	8.0	13.4	58	35	3.2	3.0	15	6	9	33	-30	90	54	22070.0436
M16	8.0	13.4	58	35	3.2	3.0	20	6	4	23	-30	90	55	22070.0440
M16	8.0	13.4	83	35	3.2	3.0	20	6	11	43	-30	90	69	22070.0442
M16	8.0	13.4	98	35	3.2	3.0	25	6	13	41	-30	90	81	22070.0444
M16	8.0	13.4	98	35	3.2	3.0	30	6	13	47	-30	90	83	22070.0450

¹⁾ statistical average value

d ₁	d ₂	Dimensions					Stroke s [mm]	WS [mm]	Spring load ¹⁾		min. max. [°C]		[g]	Art. No.
		d ₃	l ₁	l ₂	n	t			F ₁ ~ [N]	F ₂ ~ [N]				
M16	8.0	13.4	118	35	3.2	3.0	30	6	24	110	-30	90	97	22070.0452
M16	8.0	13.4	148	35	3.2	3.0	40	6	13	63	-30	90	117	22070.0455
M16	8.0	13.4	148	35	3.2	3.0	50	6	7	43	-30	90	119	22070.0460
M24	10.0	19.6	60	45	3.7	3.0	15	8	14	87	-30	90	132	22070.0480
stainless steel, standard spring load, with thread lock														
M10	4.0	7.8	35	25	1.5	1.4	8	3	6	16	-30	90	13	22070.0208
M12	5.5	9.5	43	35	2.7	2.0	10	4	4	18	-30	90	23	22070.0212
M16	8.0	13.4	48	35	3.2	3.0	10	6	7	24	-30	90	47	22070.0230
M16	8.0	13.4	58	35	3.2	3.0	15	6	9	33	-30	90	54	22070.0236
M16	8.0	13.4	58	35	3.2	3.0	20	6	4	23	-30	90	55	22070.0240
M16	8.0	13.4	98	35	3.2	3.0	25	6	13	41	-30	90	82	22070.0244
M16	8.0	13.4	98	35	3.2	3.0	30	6	13	47	-30	90	84	22070.0250
M16	8.0	13.4	148	35	3.2	3.0	40	6	13	63	-30	90	118	22070.0255
M16	8.0	13.4	148	35	3.2	3.0	50	6	7	43	-30	90	119	22070.0260
M24	10.0	19.6	60	45	3.7	3.0	15	8	14	87	-30	90	134	22070.0280
body from free cutting steel, heavy spring load, with thread lock														
M10	4.0	7.8	35	25	1.5	1.4	8	3	12	22	-30	90	13	22070.0508
M12	5.5	9.5	43	35	2.7	2.0	10	4	7	46	-30	90	23	22070.0512
M16	8.0	13.4	48	35	3.2	3.0	10	6	10	43	-30	90	47	22070.0530
M16	8.0	13.4	58	35	3.2	3.0	10	6	14	84	-30	90	54	22070.0532
M16	8.0	13.4	58	35	3.2	3.0	15	6	10	57	-30	90	55	22070.0536
M16	8.0	13.4	58	35	3.2	3.0	20	6	8	33	-30	90	56	22070.0540
M16	8.0	13.4	83	35	3.2	3.0	20	6	18	72	-30	90	71	22070.0542
M16	8.0	13.4	98	35	3.2	3.0	25	6	20	70	-30	90	81	22070.0544
M16	8.0	13.4	98	35	3.2	3.0	30	6	20	80	-30	90	83	22070.0550
M16	8.0	13.4	148	35	3.2	3.0	40	6	21	113	-30	90	121	22070.0555
M16	8.0	13.4	148	35	3.2	3.0	50	6	13	75	-30	90	121	22070.0560
M24	10.0	19.6	60	45	3.7	3.0	15	8	40	192	-30	90	134	22070.0580
stainless steel, heavy spring load, with thread lock														
M10	4.0	7.8	35	25	1.5	1.4	8	3	12	22	-30	90	13	22070.0308
M12	5.5	9.5	43	35	2.7	2.0	10	4	7	46	-30	90	23	22070.0312
M16	8.0	13.4	48	35	3.2	3.0	10	6	10	43	-30	90	47	22070.0330
M16	8.0	13.4	58	35	3.2	3.0	15	6	10	57	-30	90	55	22070.0336
M16	8.0	13.4	58	35	3.2	3.0	20	6	8	33	-30	90	55	22070.0340
M16	8.0	13.4	98	35	3.2	3.0	25	6	20	70	-30	90	82	22070.0344
M16	8.0	13.4	98	35	3.2	3.0	30	6	20	80	-30	90	83	22070.0350
M16	8.0	13.4	148	35	3.2	3.0	40	6	21	113	-30	90	122	22070.0355
M16	8.0	13.4	148	35	3.2	3.0	50	6	13	75	-30	90	122	22070.0360
M24	10.0	19.6	60	45	3.7	3.0	15	8	40	192	-30	90	135	22070.0380
body from heat treated steel, standard spring load, without locking														
M16	7.3	13.4	80	35	3.2	3.0	11	8	17	74	-	250	69	22070.0610
M16	7.3	13.4	120	35	3.2	3.0	21	8	21	81	-	250	96	22070.0612
M16	7.3	13.4	150	35	3.2	3.0	31	8	21	89	-	250	117	22070.0614
M16	7.3	13.4	200	35	3.2	3.0	41	8	16	80	-	250	149	22070.0616
M22	9.0	19.0	130	50	3.5	4.0	21	8	80	214	-	250	211	22070.0630
M22	9.0	19.0	168	50	3.5	4.0	31	8	70	210	-	250	278	22070.0632
M22	9.0	19.0	226	50	3.5	4.0	41	8	76	208	-	250	358	22070.0634

¹⁾ statistical average value

Accessories

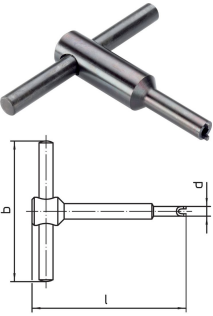
	Dimensions				[g]	Art. No.
	d ₁	b	d	l		
Assembly Tool for mounting via slot (pin sided)						
	M10	80	7.8	70	87	22070.0830
	M12	80	9.5	75	88	22070.0832
	M16	80	13.4	95	110	22070.0834
	M22	100	19.0	100	245	22070.0836
	M24	100	19.9	100	258	22070.0838

Application example

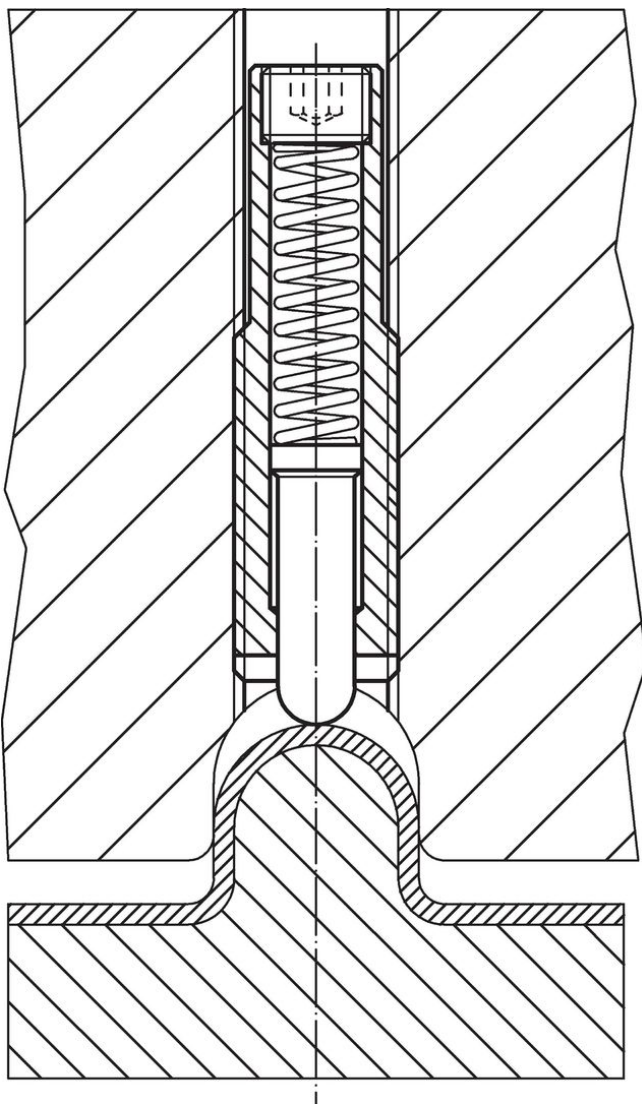

Compliance

For detailed compliance information please select the desired article number.